

VerroMax Ductwork Fabrication/Installation Instructions



Fabrication Instructions

Cut two lengths of profile to suit the duct width less 30-32mm (W), and two lengths to suit the duct height less 30-32mm (H).

Note: External dimensions of the duct are to be used.

The profile should be cut in the direction shown to prevent the metal cuttings contaminating the sealant. For best results use a circular cut off saw with pneumatic vice. The use of an abrasive blade or wheel should not be used, the heat can melt the sealant and affect the airtightness of the completed joint. If any burring has occurred during the cutting of the flange, this must be removed before assembly.

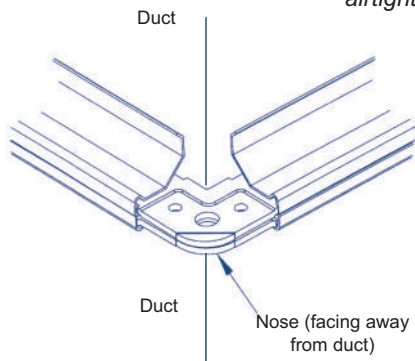

Fully insert four corners into the flange to form a rectangle frame as shown. Care must be taken to ensure the legs of the corners are fully inserted into the flange, the 'nose' on the corner faces away from the duct on which the frame is to be fitted.

To comply with DW/144 corner pieces should be fixed into the flange. Corners can be secured into profile by dimpling if preferred (machine reference DS145-147).

The frame is now ready to be fitted to the duct. Starting in one corner, the frame should be firmly tapped home by working away from the corner. On larger ducts a straight edge should be used to ensure the frame is on 'flat'.

The frame can be attached to the duct by various methods, spot welding, rivet or clinch. Spacing for fastenings to be as DW144 Table 5.

Any burrs caused during the drilling for fixings should be removed from all surfaces before finally fixing the frame to the duct. Sealant should be applied if any method of fixing pierces the duct.

When the frame is securely fixed, a fillet of mastic needs to be run along the cut end of the flange on the inside of the duct, a further fillet of sealant is required around the corner piece where it meets the duct on the inside.

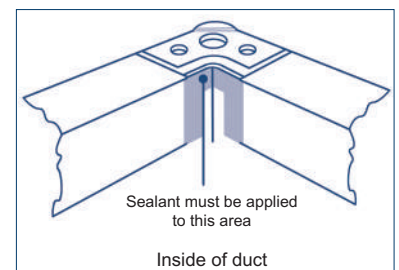
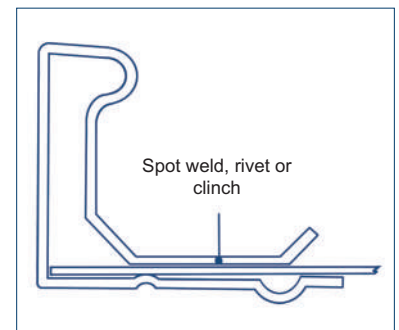
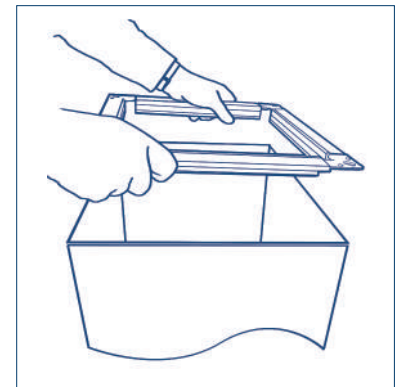
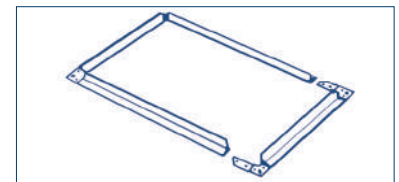
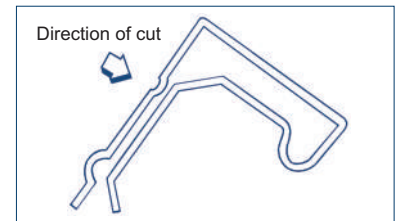
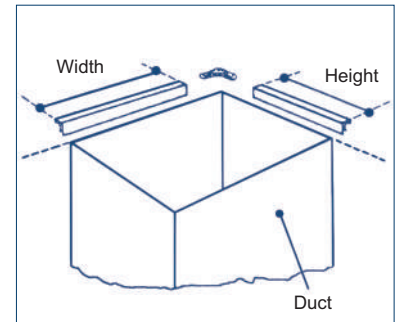

VerroMax Ductwork Jointing System

Site Installation

When using VF20LC, VF30C and VF40C corners the Verrolec gasket 570 (9mm x 4.5mm) is used. The gasket is fitted as one continuous length. To complete the seal there should be a minimum overlap of 30mm where the two are in contact. For working duct pressures of 1000PA and above, additional gasket should be applied to the four corners extending 30mm from the corner onto the flange.

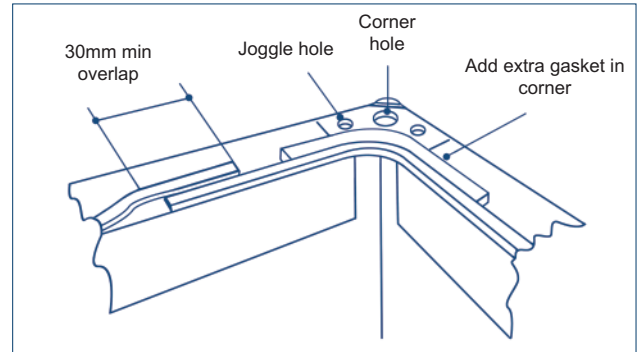

Assemble the ductwork by the use of nuts and set screws fitted into the corner holes. If necessary align the corner holes by use of the joggle holes. The nuts and screws should be finger tight at this point.

Use M8x25mm set screw for VM20

Use M10x25mm set screw for VM30

Use M8x25mm set screw for VM40

CLIP / CLAMP / CLEAT SELECTION

Profile	506	508	505
VM20	✓	✓	
VM30	✓	✓	*
VM40			✓

* Use for inaccessible areas

Fixings should not exceed 400mm centres.

To fit the 506, 508, and drive cleat to two sides of the duct, remove one corner set screw and slide the drive cleat across the profile. Compress the nose of the profile together by using molegrips or similar.

Repeat this operation for the other two sides. Finally tighten the corner nuts and set screws.

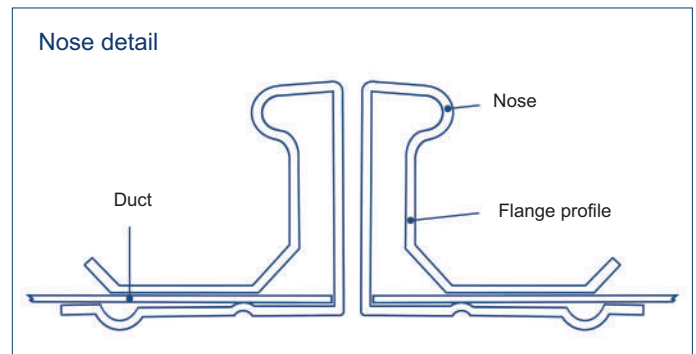

Safety

Please make sure you are wearing adequate PPE clothing when handling any exposed metal edges as these can sometimes be sharp.

Site Installation



Doby Verrolec, Harelaw Industrial Estate, Stanley, Co Durham DH9 8UJ England

Tel: +44 (0)1207 238844 Fax: +44 (0)1207 283563 e-mail: enq@dobyverrolec.com Websites: www.dobyverrolec.com & www.dobygrip.com

The information contained herein is subject to change without prior notice due to continuing research and development. Doby Cleats Ltd trading as Doby Verrolec Registered in England Number 952089



DobyGrip®

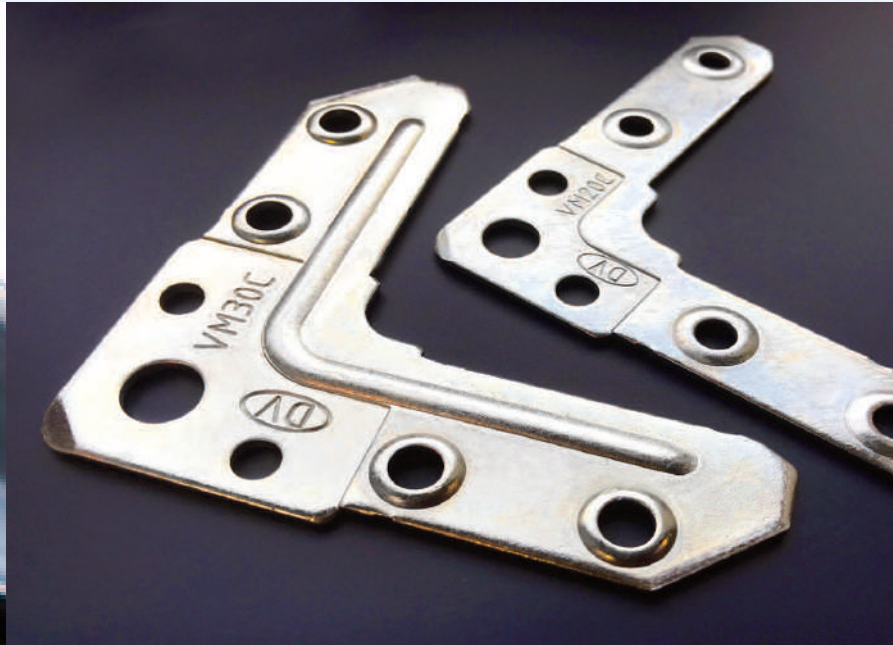

Doby Verrolec, Harelaw Industrial Estate, Stanley,
Co. Durham. DH9 8UJ England

Tel: +44 (0) 1207 238844

Fax: +44 (0) 1207 283563

e-mail: enq@dobyverrolec.com

Web: www.dobygrip.com www.dobyverrolec.com www.dobysolutions.com