

Ductwork Components

'S' Type Stiffener

Profile & Corner Details and Specifications

- No Secondary protection of the stiffener required.
- DVS4 capable of reaching S5 rating at medium pressure.
- Manufactured to comply with Fig.26 of B&ES specification DW/144 2013.
- Specifically designed EZP corner pieces.
- More convenient - Stiffener can be fitted after ductwork is completed.
- Pre-drilled pilot holes for easier fitting as standard.
- Stiffener frame can be made up using fasteners or spot welded together reducing time to assemble over using a welded RSA frame.
- Cost savings - By allowing the use of shorter fasteners than when using RSA.
- Fixing centres rolled into the stiffener during manufacture, reducing fitting time if pre-drilled pilot holes are not required.
- Easier and quicker fitting time by drilling stiffener and ductwork for fasteners in single operation.

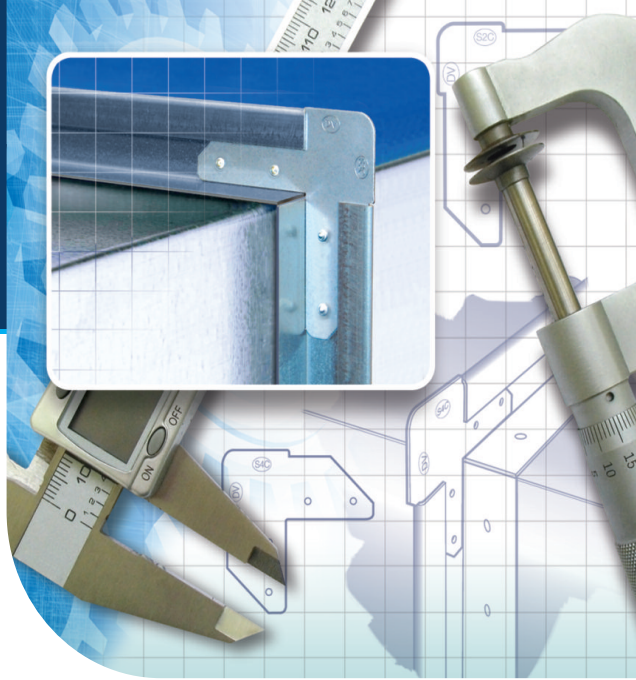

Dimensions

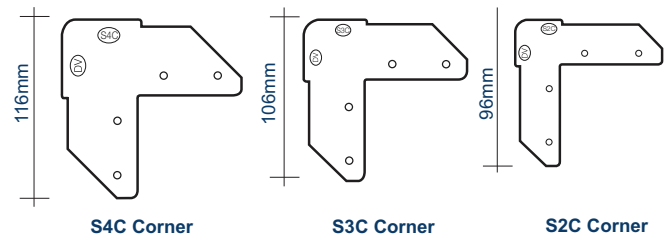
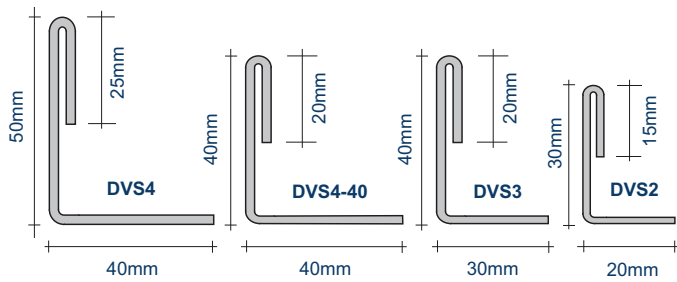

Specification

Stiffener Rating Table

Stiffener Rating	Pressure (Pa)			Corner
	500	1000	2000	
S2	DVS2	DVS2	DVS2	S2C
S3	DVS3	DVS3	DVS3	S3C
S4	DVS4	DVS4	DVS4	S4C
S4	DVS4-40	DVS4-40	DVS4-40	S3C
S5	DVS4-40			S3C
S5	DVS4	DVS4		S4C

Packing

Profile	Gauge	Weight (Kg)	Profiles	Corners
DVS2	1.6mm	0.804/m	250m 5m	200/10.0kg
DVS3	1.6mm	1.080/m	250m 5m	200/14.5kg
DVS4-40	2mm	1.586/m	250m 5m	200/14.5kg
DVS4	2mm	1.758/m	250m 5m	100/11.5kg

Profiles - British Standard BS EN 10142:2000 Steel grade and coating specification: BS EN 10346:2015 DX51D +Z275 MAC. **Corners** - Hot rolled steel to BS EN 10111:2008 Steel grade EN 10111-DD11 Pickled and Oiled finish - Zinc and clear passivate to BS EN 2081:2008 - Fe/Zn8/A.

Application

The 'S' Type Stiffener when fitted to the outside of ductwork and between the cross joints it strengthens the ductwork and reduces vibration.

Unlike rolled steel angle, the Stiffener provides a simple and economical answer to ductwork stiffening - with no need for any secondary protection.

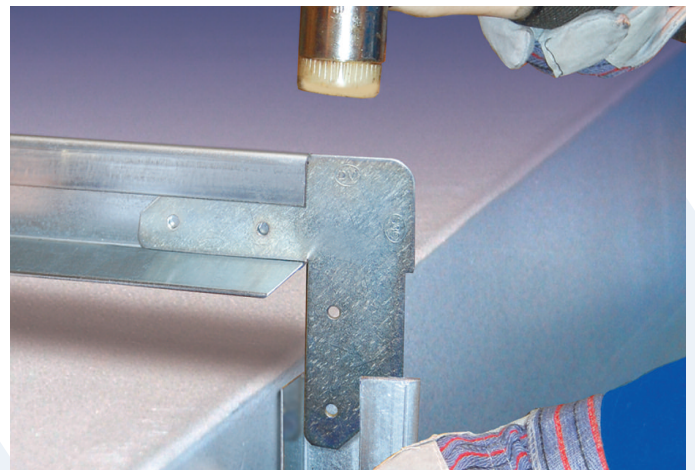

Stiffener Fixing Details

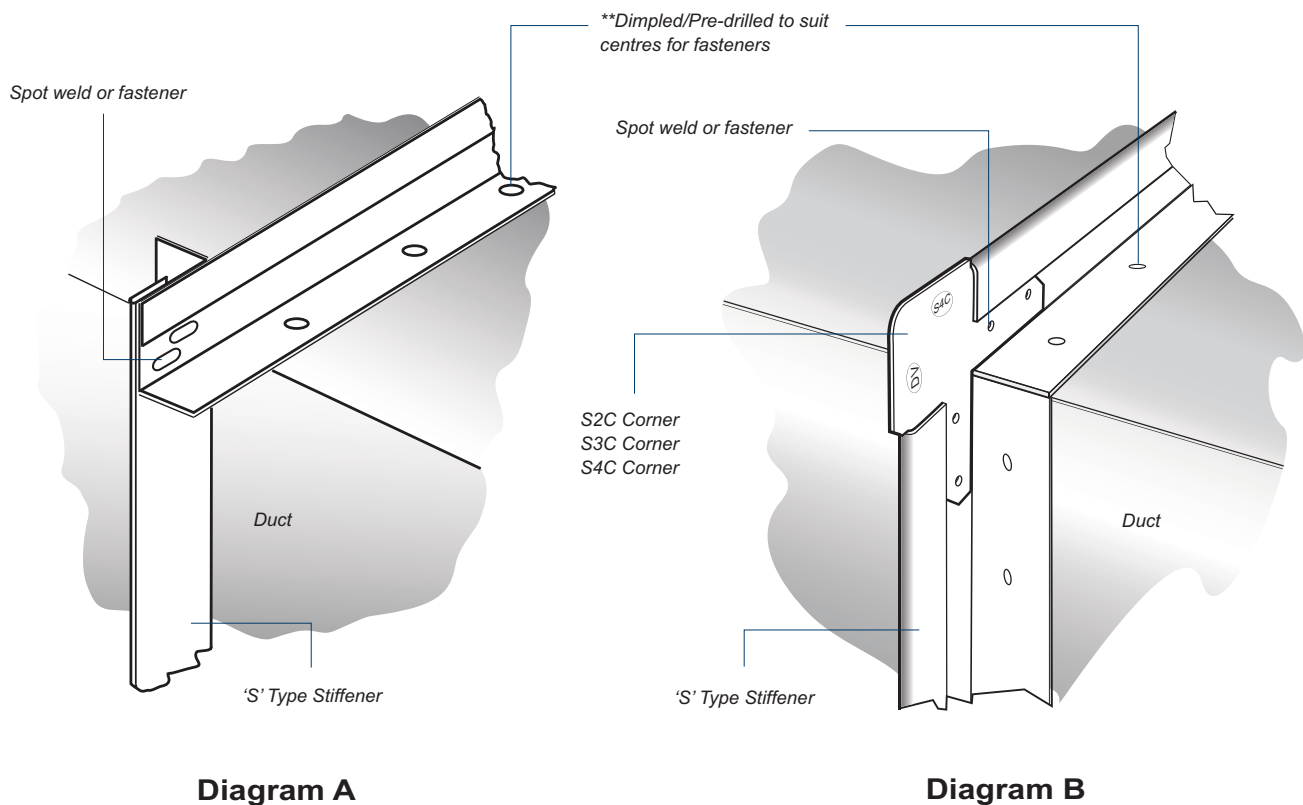

Diagram A

Diagram B

Fabrication

Diagram A:

Selecting the most appropriate profile, cut the lengths based on the duct dimensions + twice the stiffener height. Position the length of stiffener at right angles to the duct, with equal overhang. Using the ****Dimpled centres/Pre-drilled holes** fix the profile to the duct with rivets or an alternative fixing method. Repeat the procedure on the opposite duct face using identical length stiffener. Position each of the remaining pieces back to back with the profiles already attached and then fix to the duct. In each frame corner spot weld or use another appropriate fastener to connect the four profiles together.

Diagram B:

Cut the stiffener to external dimensions of the duct, then insert the corners to form three sides of the frame. Place around duct and insert the fourth side of the frame with the corners to complete the assembly. Using the ****Dimpled centres/Pre-drilled holes** fix the profile to the duct with rivets or an alternative fixing method.

****Stiffener profiles can be supplied with either Dimpled fixing centres or Pre-drilled pilot holes to suit individual fixing requirements.**

Please Note:

Make sure you are wearing adequate PPE clothing when handling metal products to minimise the risk of injury.